

## Accesorios Incluidos / Included Accessories

\*4 tornillos de montaje 12 - 24 pavonado negro

\*4 mounting screw 12 - 24 black blued



EVOLVING TO LEADERSHIP...

## Características Generales / General Features

**MATERIAL:** ACERO AL CARBÓN CAL. 18 (1.22 mm) **MATERIAL:** CARBON STEEL, CAL. 18 (1.22 mm)

**CAPACIDAD DE CARGA:** 6 kg. / 13.22 lb.

**Laod Capacity:** 6 kg. / 13.22 lb.

MODELO / PART	UR	DIMENSION / DIMENSION	ANCHO / WIDTH	ALTURA / HEIGHT	PROFUNDIDAD / DEPTH	PESO / WEIGHT
NORTH 103	1	19"	483 mm	53 mm	52 mm	1.08 kg. / 2.38 lb.
NORTH 104	1	23"	584 mm	53 mm	52 mm	1.17 kg. / 2.57 lb.

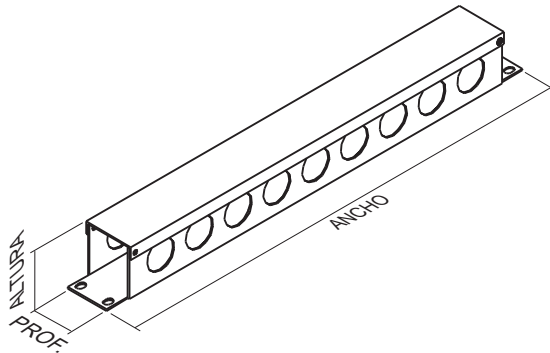

Resistencia Ambiente / Weather Resistance	<b>CLAVE</b>	Color / Color	<b>CLAVE</b>	Acabado / Finished	<b>CLAVE</b>
Polvo Industrial / Industrial dot	DI	Negro / Black	BK	Liso / Smooth	L
Humedad / Humidity	WI	Beige / Beige	BE	Texturizado / Textured	TX
Grado clínico / Clinical grade	HN +				
Normal 1 a 40° C / Normal 33 to 104 ° F	CL =				

Existen mejoras en la resistencia del ambiente, colores personalizados y fabricación en materiales especiales. Consulte a su vendedor, todo cambio fuera de catalogo, cotizado y pedido aparte.  
 Exist improved environmental resistance, custom colors on special materials and manufacturing. Consult your dealer, any change out of print, quote and order separately.

# ORGANIZADOR DE CABLES CON TAPA ABATIBLE CABLE MANAGEMENT WITH HINGED LID



NUMERO DE PARTE:

## NORTH 103 Y NORTH 104

INDUSTRIA: De la automatización, sistemas, telefonía, telecomunicaciones, computación, redes, audio, área medica.

INDUSTRY: Automation, systems, telephony, telecommunications, computing, networking, audio, medical area.

Pregunte por los accesorios originales de la compañía North para las necesidades de su negocio.

Ask for the company's original accessories North for your business needs.

[www.northsystem.com.mx](http://www.northsystem.com.mx)

ISO  
9001 : 2008  
REGISTERED



[ventas@northsystem.com.mx](mailto:ventas@northsystem.com.mx)